

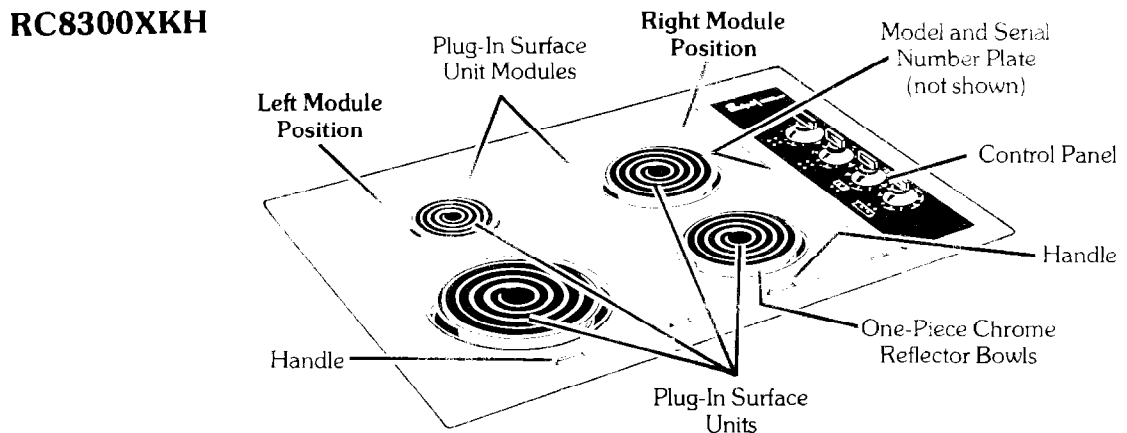

MODULAR COOKTOPS
Models **RC8800XKH** (3 Modular Unit)
RC8300XKH (2 Modular Unit)

USE AND CARE GUIDE

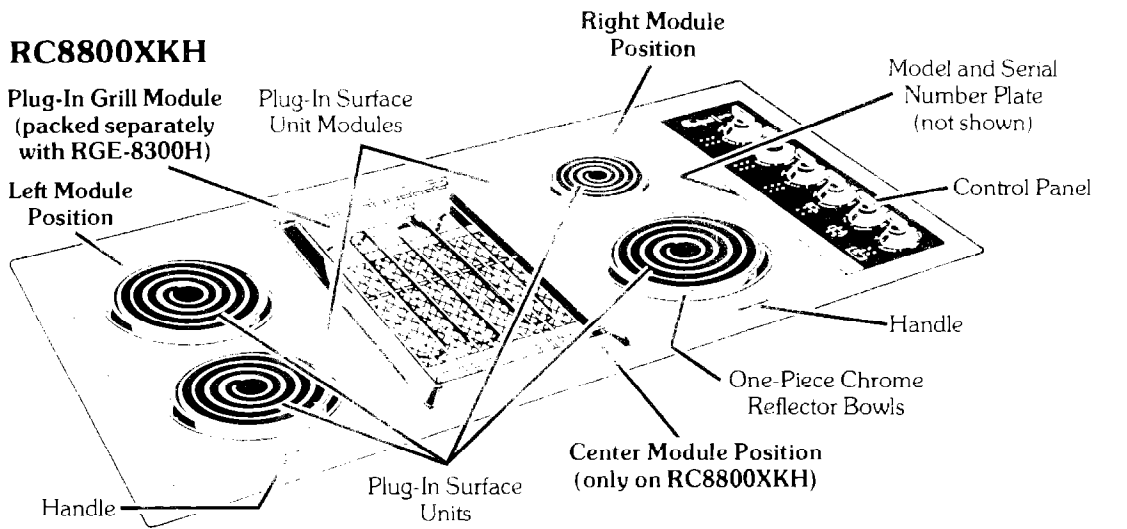

RC8300XKH

Surface Unit Control Knobs

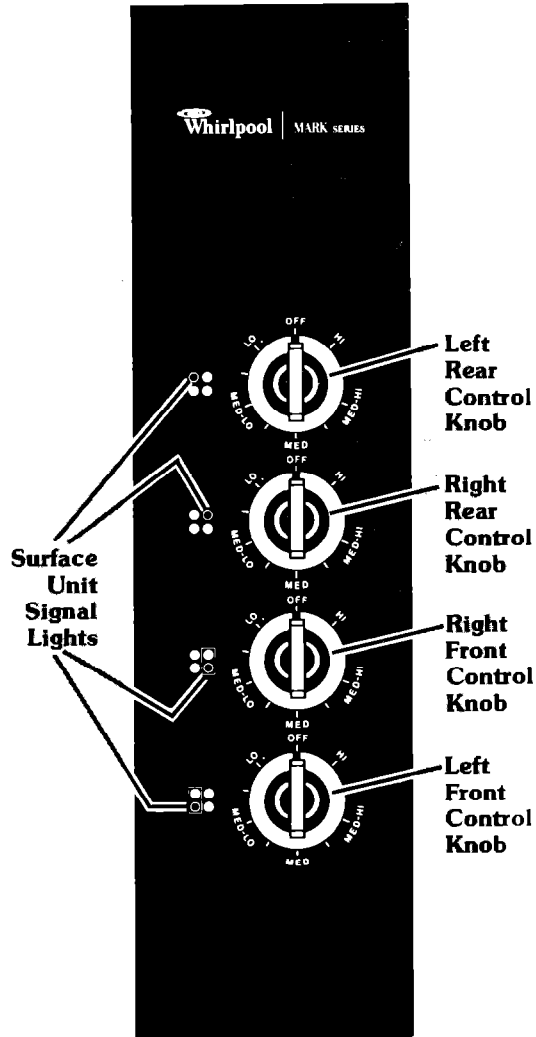

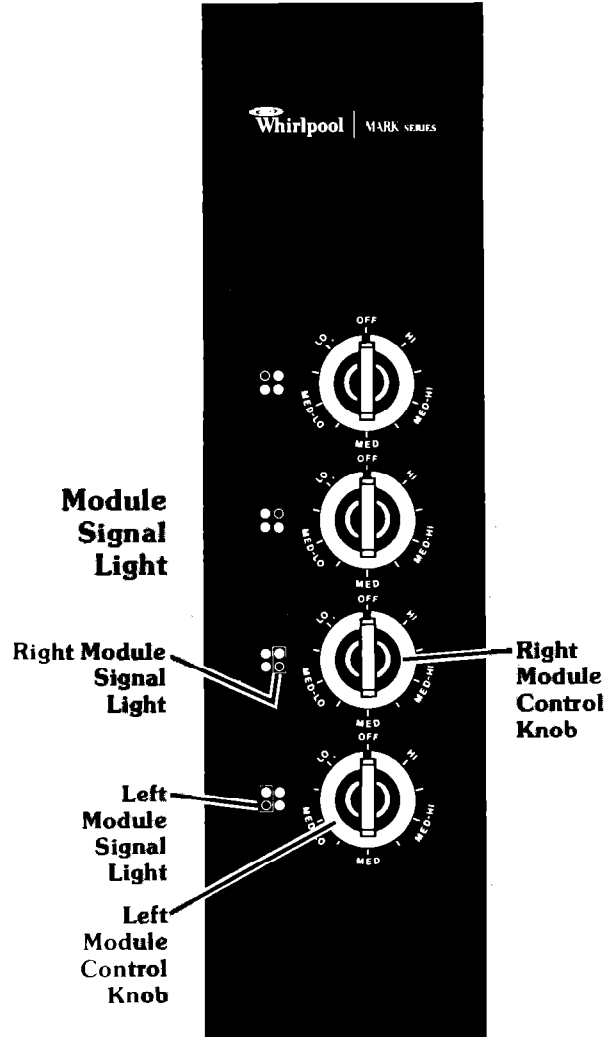

Grill/Griddle Control Knobs



Signal Lights will glow when a surface unit or module is on. Check these lights and the design to the left of the knob to indicate which unit or module is on.

The design to the left of the knob indicates which unit is controlled by that knob. (For example,  indicates the left rear surface unit.)

The rectangular boxes,  or , indicate which control knob to use for the grill or griddle. The grill or griddle may be used in either the left or right positions. Use the Module Control Knob which corresponds with the grill or griddle placement.

RC8800XKH

Surface Unit Control Knobs

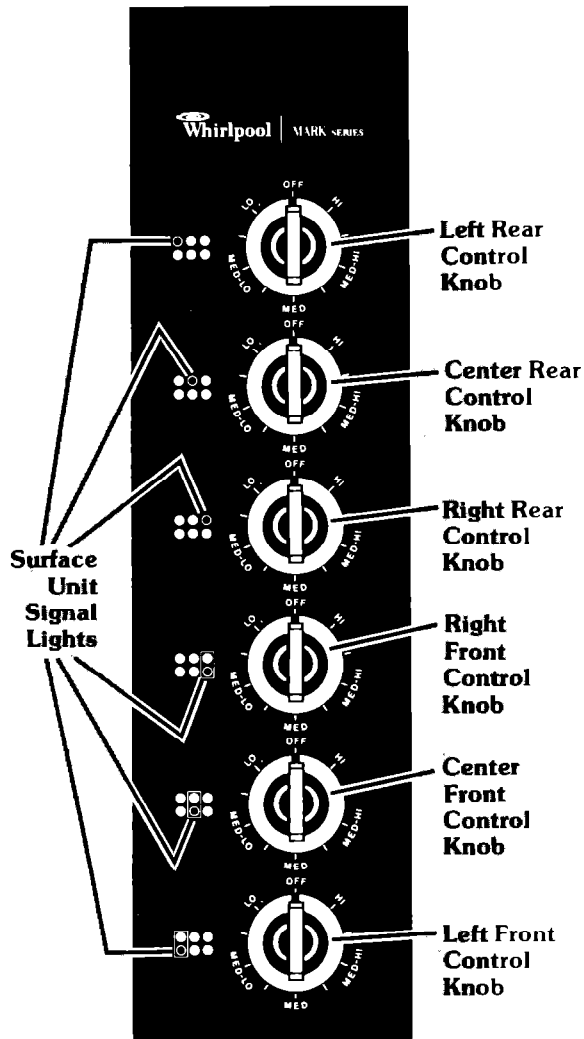

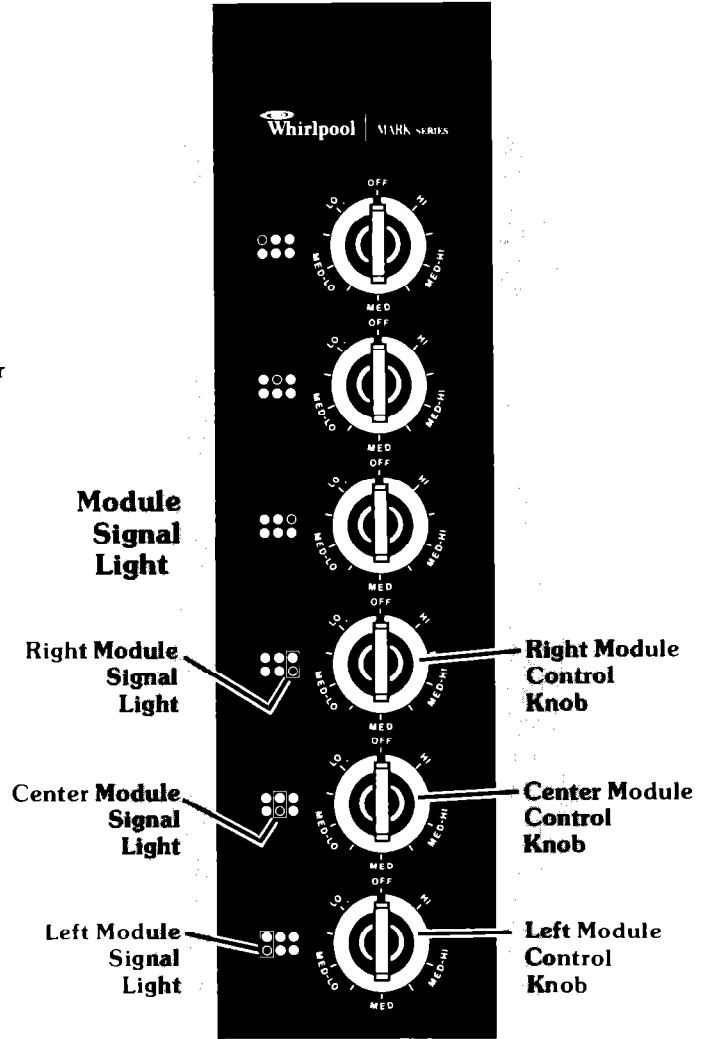

Grill/Griddle Control Knobs



Signal Lights will glow when a surface unit or module is on. Check these lights and the design to the left of the knob to indicate which unit or module is on

The design to the left of the knob indicates which unit is controlled by that knob. (For example,  indicates the left rear surface unit.)

The rectangular boxes , , or , indicate which control knob(s) to use for the grill(s) or griddle. The grill(s) and griddle may be used in any module position. Use the Module Control Knob which corresponds with grill or griddle placement.

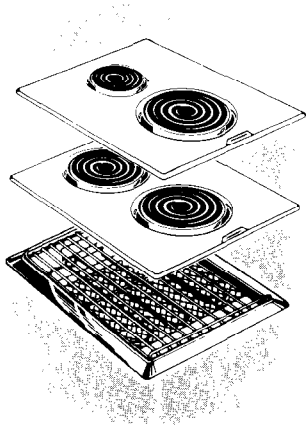

Your cooktop has two or three sections which are called modules. One module has two 6-inch surface units, another has a 4-inch and an 8-inch surface unit, and the grill is another module. All the modules are interchangeable and can be installed in any position in your cooktop.

Additional modules may be purchased from your dealer. Optional items include: a griddle module; a rotisserie accessory for the grill; an extra grill; a cutting board; and additional surface unit combinations.

Please read this Use and Care Guide for further instructions.

Contents

	Page
IMPORTANT SAFEGUARDS	4
BEFORE YOU USE YOUR COOKTOP	6
HOW TO USE SURFACE UNIT CONTROLS	7
HOW TO USE THE GRILL	7
HOW TO REMOVE AND REPLACE MODULES	9
HOW TO CLEAN AND CARE FOR YOUR COOKTOP	10
OPTIONAL GRIDDLE	12
OPTIONAL ROTISSERIE	13
OPTIONAL CUTTING BOARD	15
IF YOU NEED SERVICE OR HELP	15
1. Before you call for service	15
2. If you need service	16
3. If you have a problem	16

IMPORTANT SAFEGUARDS

Safety is everyone's responsibility. Whirlpool has researched and designed your cooktop to help you prepare meals easily and safely. You, as the owner of the cooktop, also have a responsibility to use it and care for it wisely.

For your own and your family's safety, read and follow these Do's and Don'ts.

DO

1. Remove the Consumer Buy Guide label before using your cooktop.
2. Have your appliance properly installed, electrically grounded and connected to the supply of electricity by a qualified person.
3. Think about the clothes you are wearing when using a cooking appliance. Never wear loose fitting or hanging garments while using the cooktop. The fabric could accidentally touch a hot heating element and burn or catch on fire.

- 1 Use only dry pot holders. Using damp potholders on hot surfaces may result in burns from steam. Do not let the potholder touch hot elements. Avoid using a towel or other bulky cloth for a potholder.
- 5 Use flat-bottomed pans that are the proper size for the amount of food that you are cooking. Also, select a surface unit that is about the same size as the pan you are using. Using a pan that is about the same size as the surface unit will make more efficient use of electricity. If a pan is smaller than the surface unit, some of the hot heating element would be exposed and could cause a burn, overheat a pan handle, etc.
- 6 Make sure the reflector bowls are in place during cooking. Cooking without reflector bowls may subject the wiring and components underneath them to damage.
- 7 Check to be sure glass cooking utensils are safe for use on the cooktop. Only certain types of glass, glass ceramic, ceramic, earthenware or other glazed utensils are suitable for cooktops. Other kinds of glass may break as a result of a sudden change in temperature.
- 8 Turn pan handles inward, yet not over other surface units. This will help minimize the possibility of burns, ignition of flammable materials, and spills due to accidentally bumping the pan.
- 9 Always check the position of the cooktop control knobs and the indicator lights to make sure cooktop is off when you are finished cooking.
- 10 Use aluminum foil to line surface unit reflector bowls *only* as suggested in the instructions you receive with your appliance. Improper installation of these liners may result in a shock or fire hazard.
- 11 Turn on surface unit only *after* placing filled utensil on the unit. Turn "OFF" before removing the utensil from the surface unit.
- 12 **CAUTION: Do clean all parts of the grill after each use. If not cleaned, fat drippings can become rancid, develop an odor, or become a fire hazard.**

DON'T

- 1 Never use your cooktop to warm or heat the room.
- 2 Do not touch surface heating units. They may be hot even though they are dark in color and appear cool. Also, the trim ring, the cooktop or areas near the heating units may become hot enough to cause burns.
- 3 Do not let clothing or other flammable materials contact surface units, or areas near these units while they are being used, or until the elements have had sufficient time to cool after use.

4. Do not leave children alone or unattended in the area where the cooktop is in use. They should never be allowed to sit or stand on any part of the appliance. Do not let children play with the cooktop. It is not a toy!
5. Do not repair or replace any part of the appliance unless it is specifically recommended in literature you receive with it. All servicing should be referred to a qualified technician.
6. Don't store flammable materials near surface units.
7. Do not use water on grease fires. Smother the fire or flame, or use a dry chemical or foam-type extinguisher.
8. Never leave surface units unattended at high heat settings. A boilover causes smoking and greasy spillovers that may ignite.
9. Do not soak removable heating elements in water.
10. Do not heat unopened food containers, such as baby food jars and cans. Pressure build-up may cause the container to burst and result in injury.
11. **CAUTION:** Do not store items of interest to children in cabinets above a cooktop or near the surface units. Children could be seriously injured while climbing on a cooktop to reach these items.

Before using your cooktop

IMPORTANT

We build appliances to last, but we can't control how they are used. Before using it, you are personally responsible for making sure that it...

- is properly installed and leveled in a countertop and cabinet that will hold the weight, and in a well-ventilated room.
- is wired with the right electric supply and grounding.
- is used only for jobs expected of home cooktops.
- is out of the weather.
- is properly maintained.
- is **not** used by children or others who may not understand how it should be used.

SAFETY FIRST

- **Do not let children use or play with the cooktop.**
- **Use your cooktop only for the job it is intended to do.**
- **Read the Installation Instructions for complete information.**

How to use surface unit controls

The control knobs on your modular cooktop have a feature—required on all ranges and cooktops—to help keep children from accidentally turning on the surface units. **You must push in (down) on them first, then turn to the desired setting.**

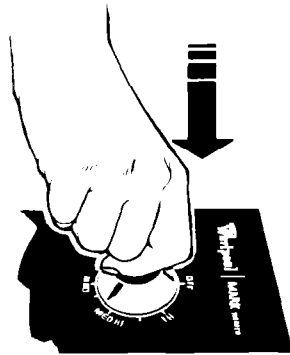

To turn on surface unit PUSH IN and turn to desired setting.

The design to the left of each knob indicates which unit is controlled by that knob. (For example, ●●● indicates the right front unit on the RC8800XKH [three module unit] or ●● on the RC8300XKH [two module unit].)

The control may be set anywhere between “HI” and “LO” to select the exact amount of heat required.

As you use your cooktop, you will find the correct settings for the cooking you do. Recommended settings you can use as a guide are:

- HI** — To start most foods cooking. To bring water to a boil.
- MED HI** — To hold a rapid boil; to fry pancakes; to fry chicken.
- MED** — To make gravy, puddings and icings; to cook large quantities of vegetables.
- MED LO** — To keep food cooking after starting at a higher setting.
- LO** — To keep food warm until ready to serve. Adjust heat higher or lower within the LO area as needed for different foods.

A 4-inch surface unit is a special feature on your cooktop. Designed only for small pans, it may be used to:

- warm coffee pot, small tea kettle, oven proof casseroles.
- melt chocolate, cream cheese, butter, marshmallows at low temperatures.

The Signal Light to the left of each Surface Unit Control Knob will glow whenever the surface unit is on. Be sure all lights are off when you have finished cooking.

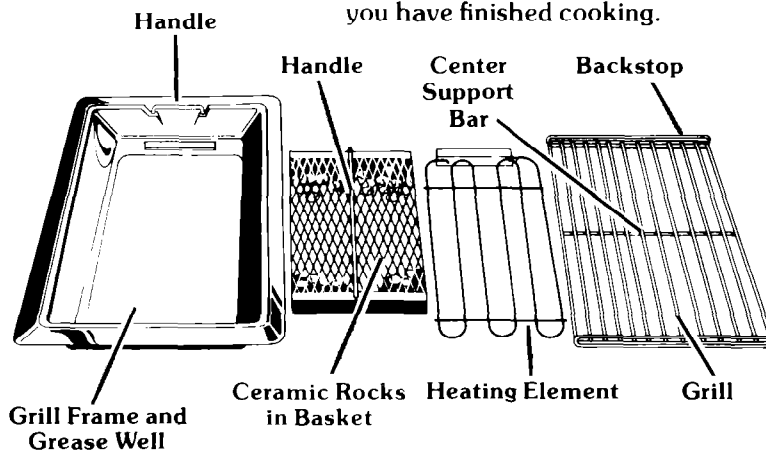

How to use the grill

To use the grill:

The Grill Module has four parts:

- grill frame and grease well
- ceramic rocks in the basket
- heating element
- grill

A hood is recommended for use with the grill to help eliminate smoke during grilling. Model RGH-8330 or RGH-8336 are for use with the two module cooktop Model RC8300XKH, and hood Model RGH-8348 is for use with the three module cooktop Model RC8800XKH.

The grill should be taken apart and cleaned after each use (see page 9, “To remove or replace a Grill Module”).

To operate the grill:

You must push in (down) on the Module Control Knob, then turn to the desired setting. The design with the left of the control knob indicates which knob to use (example ●●● or ●●). See chart for approximate cooking times.

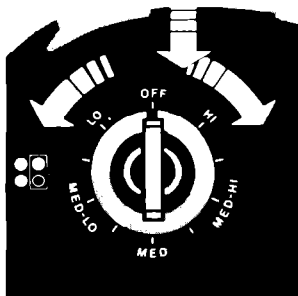

Approximate grill cooking times

(NOTE: Preheat grill for five minutes at suggested control setting.)

GRILL FOOD	Internal Temperature	Weight or Thickness	Control Setting	Approximate Side 1	Cooking Time Side 2	Comments
Beef						
Steak						
Rare	140°F	1"	Hi	8 Min.	9 Min.	To test steak for doneness, cut near center with sharp knife
Medium	160°F	1"	Hi	11 Min.	12 Min.	
Well-Done	170°F	1"	Hi	12 Min.	13 Min.	
Steak						
Rare	140°F	1½"	Hi	10 Min.	7 Min.	
Medium	160°F	1½"	Hi	13 Min.	13 Min.	
Well-Done	170°F	1½"	Hi	16 Min.	16 Min.	
Hamburgers						
Rare	140°F	3" x 1" Thick	Hi	8 Min.	10 Min.	
Medium	160°F	3" x 1" Thick	Hi	9 Min.	12 Min.	
Well-Done	170°F	3" x 1" Thick	Hi	10 Min.	13 Min.	
Fish						
Whole	120°F	2½#	Hi	15 Min.	15 Min.	Do not overcook fish. When fish flakes easily it is done. Cook all fish on aluminum foil
Fillets	120°F	1#	Hi	4 Min.	4 Min.	
Lobster Tails	120°F	2	Hi	5 Min.	5 Min.	
Chicken						
Quarters or Pieces	190°F	2½#	Hi		55 Min. Total	
Pork						
Loin or Rib Chops						Turn every few minutes
Well-Done	170°F	¾" - 1"	Hi	15 Min.	12 Min.	
Spareribs	170°F	2½#	Hi	10 Min.	10 Min.	
Ham Slice, fully cooked	150°F	1#	Hi	6 Min.	7 Min.	
Sausage						
Patties	170°F	¼# ½" thick	Hi	8 Min.	12 Min.	
Links	150°F	10 oz.	Med Hi		6 Min. Total	
Other						
Frankfurters	150°F	8 Franks	Hi		8 Min. Total	Turn frequently
Sandwiches, foil wrapped		6 Sandwiches	Hi		18 Min. Total	
Potatoes, in foil & cut into pieces		4 potatoes	Hi		45 Min. Total	Wrap tightly
Corn on the Cob wrapped in foil	150°F	4 ears	Hi		30 Min. Total	
French Bread, in foil	130°F	2 loaves	Hi		10 Min. Total	

Hints and tips:

1. Cooking on the grill can produce spattering. It is important to clean all parts after each use. (See page 9, "To remove and replace the Grill Module.")
2. The ceramic rocks will darken with use.
3. The backstop or bar at each end of the grill is designed for ease in flipping hamburgers or other food products.
4. The heating element for the grill, like the surface units, cleans itself. It must not be immersed in water.
5. Take grill apart to clean and to remove and store.
6. Most utensils which are safe for use on an outdoor grill may be used with your Grill Module.

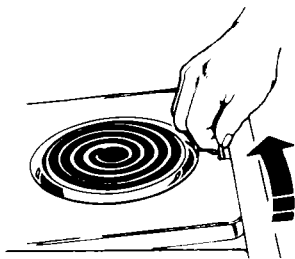

Step 1

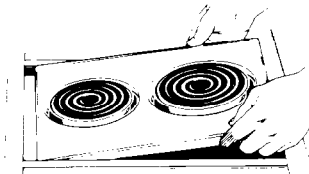

Step 2

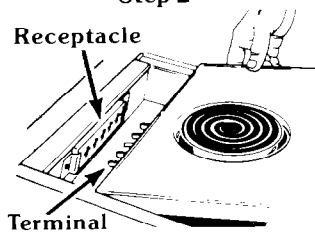

Step 3

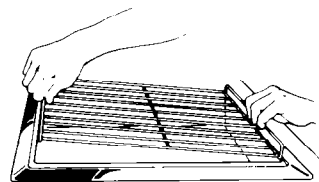

Step 1

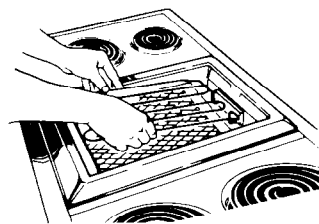

Step 2

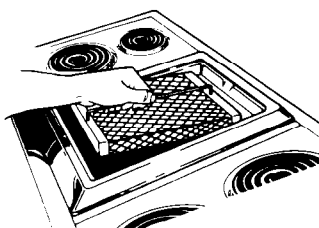

Step 3

How to remove and replace modules

Make sure all Surface Unit Control Knobs are in the "OFF" position and the modules are cool before removing or replacing.

To remove or replace Surface Unit Modules

1. To remove:

- Lift module using the handle at the front. (See Step 1.) Raise front just high enough to grasp at front edge.
- Ease module toward you using both hands to unplug it. (See Step 2.)
- Lift module out of cooktop. It may be used in any cooktop position (left, right or center on the three module unit).

2. To replace:

- Grasp module with both hands. (See Step 2.)
- Ease it into place, lining the module terminal with the receptacle on the cooktop. (See Step 3.)
- Lower the module, using the handle on the front. (See Step 1.)

To remove or replace a Grill Module

Make sure the Module Control Knob is in the "OFF" position and the module is cool before removing or replacing.

1. To remove:

- Lift the grill off the grill frame. (See Step 1.)
- Grasp the heating element with both hands, lifting slightly. Pull toward you to unplug the heating element. (See Step 2.)
- Lift ceramic rock basket from grease well, using basket handle. (See Step 3.)
- Remove grease well by lifting the module using the handle at the back. Slide grease well back about one inch and up until the tab on the front edge is clear of the cooktop frame. (See Step 4.)
- Lift grease well out of the cooktop. Remove as directed to avoid spills of fat drippings. Clean all parts after each use. (See page 10, "How to clean and care for your cooktop.")

2. To replace:

- Rest grill frame on the cooktop frame. Raise slightly at rear. Hold handle and slide forward until it stops. (See Step 5.) The front tab should slide under the cooktop frame. Release handle to lower grill frame.
- Using the handle, lower the ceramic rock basket into the grill frame. (See Step 3.) Slide basket to the front of the grill frame, leaving enough room to plug the heating element into the cooktop.
- Grasp the heating element with both hands and plug terminal into cooktop receptacle. (See Step 2.) Lower into place.
- Fit grill into groove on top of the frame. Be sure that center supporting bar on the grill faces down.

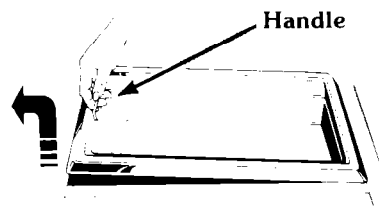

Step 4

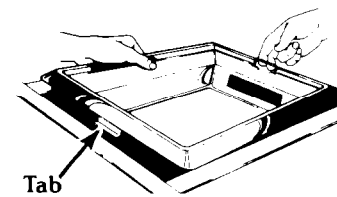

Step 5

How to clean and care for your cooktop

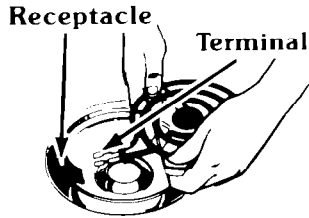
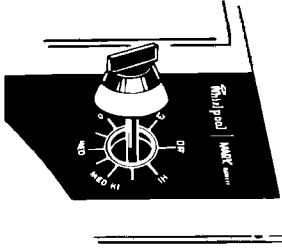

To remove surface unit, lift and pull straight out.

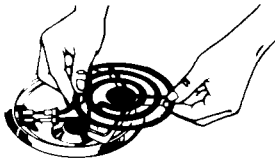

Hold surface unit level when replacing.

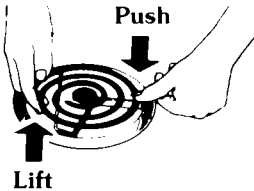

1. To remove the control knobs for cleaning:

- Be sure control knob is in the “OFF” position.
- Grasp the knob and pull straight up.
- Wash in warm, sudsy water.
- Push knob back into place (indicator line pointing to “OFF”).

2. To remove surface unit and reflector bowls:

- Be sure the control knob is in the “OFF” position and the unit is cool.
- Lift the edge of the unit (about 1 inch) opposite the receptacle. Pull the entire unit straight out. (Units clean themselves—do not immerse in water.)
- Lift out reflector bowl.

NOTE: The reflector bowls under each surface unit are designed to catch spillovers and to reflect heat into utensils for faster cooking. Frequent washing will keep them cleaner, more efficient and looking more like new.

If a reflector bowl turns blue or gold, the pan you are using may not be flat enough to make good contact with the surface unit, or it may be too large for the unit size. Heat then goes down into the reflector bowl instead of being absorbed into the pan. This results in discoloration of the bowl from high heat.

To replace surface unit and reflector bowl:

- Put the reflector bowl back into place. Line up the opening in the side of the bowl with the receptacle.
- Line up the surface unit terminal with receptacle, holding the unit level (as illustrated).
- Plug the unit into place while lifting slightly at the edge near the terminal. Push down at the edge opposite the terminal.
- Make sure the surface unit is pushed into the receptacle as far as possible. The unit should be level when replaced correctly.

PART	WHAT TO USE	HOW TO CLEAN
Frame of cooktop	Soft cloth, warm soapy water Nylon or plastic scouring pad for stubborn spots	<ul style="list-style-type: none"> • Wipe off regularly when cooktop is cool. • Do not use abrasive or harsh cleansers.
Surface units and grill heating element	No cleaning required	<ul style="list-style-type: none"> • Spatters or spills will burn off. • Do not immerse in water. • Do not place in Self-Cleaning Oven.
Griddle and griddle cover	Warm, soapy water	<ul style="list-style-type: none"> • Wash, rinse and dry well. • Do not immerse griddle in water. • Do not use steel wool, metal scouring pads or harsh cleansers. • Periodically rub non-stick finish with plastic scouring pad.
Control Knobs	Warm, sudsy water	<ul style="list-style-type: none"> • Rinse and dry well. • Do not soak.
One-piece reflector bowls (chrome plated)	Automatic dishwasher or warm, soapy water or plastic scouring pad	<ul style="list-style-type: none"> • Wash with other cooking utensils. • Clean frequently. • Do not use harsh abrasives.
Control panel	Soft cloth, warm, soapy water	<ul style="list-style-type: none"> • Wipe off frequently and dry with soft cloth.
Grill frame and grease well	Warm, soapy water and plastic scouring pad	<ul style="list-style-type: none"> • Wash, rinse and dry. • Clean frequently.
Cutting board	Soft cloth, warm soapy water To season or sterilize	<ul style="list-style-type: none"> • Wipe off after each use. • Do not soak in water. • See page 15.
Ceramic Rock Basket	Hot, soapy water; then automatic dishwasher	<ul style="list-style-type: none"> • Clean frequently. • First, soak and swish in hot, soapy water, then wash in automatic dishwasher. • Replace as needed (Part No. 1317620).
Grill	Warm, soapy water or soapy steel wool pads	<ul style="list-style-type: none"> • Wash, rinse and dry. • Use soapy steel wool pads for stubborn areas.
Rotisserie end supports and spit	Warm, soapy water and plastic scouring pad	<ul style="list-style-type: none"> • Wash, rinse and dry. • Clean frequently.
Rotisserie motor	Soft cloth, warm soapy water	<ul style="list-style-type: none"> • Wipe off frequently. • Unplug before cleaning.

DO NOT PLACE MODULE OR PARTS IN A SELF-CLEANING OVEN.

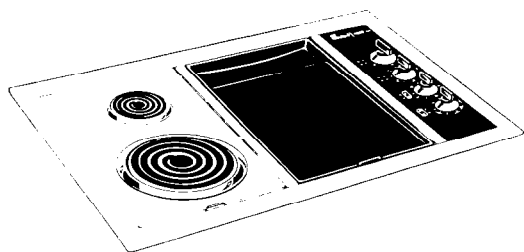

How to use the optional griddle

The griddle (Part No. 261950) can be used in any position of either unit. Make sure the correct control knob is used ☼☼, ☼☼☼, or ☼☼☼.

Before you use the griddle the first time:

1. Wash it with hot sudsy water, using a sponge or dish cloth. Do not immerse griddle in water. (See below, "To clean the griddle.")
2. Rinse and wipe dry.
3. Brush griddle with a light coating of cooking oil to season. It is not necessary to grease the non-stick finish each time the griddle is used. However, oil, fat or butter will add flavor to food and is an aid in browning.

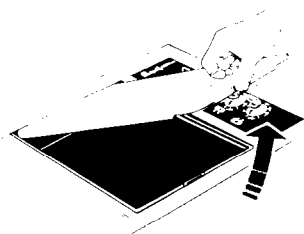

To use the griddle:

1. **Lift and remove the griddle cover before preheating or cooking.**
The cover should **not** be replaced until the griddle is cool.
2. Preheat griddle for a few minutes. (Until butter melts or a few drops of water sprinkled on the surface dance in little round beads.)
3. Add food. **Use only nylon or plastic utensils.** Metal utensils may scratch the non-stick finish. Do not leave utensils on the hot griddle. They may melt.
4. Turn unit off when finished. An empty griddle can be damaged by long periods of high heat. Replace griddle cover only after griddle has cooled.
5. Use the following table as a cooking guide for the griddle. Use higher or lower settings as needed for your recipes.

Eggs	Medium (Preheat only until fat melts.)
Bacon	High
Grilled Sandwiches	High
Pancakes	High
Hamburgers	Medium High

The Signal Light to the left of the Module Control Knob will glow whenever the griddle is on. Be sure this light is off when you have finished cooking.

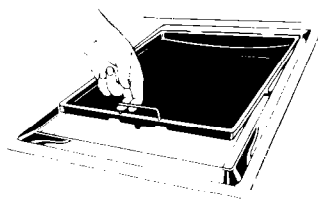

To remove griddle, lift at front and pull toward you.

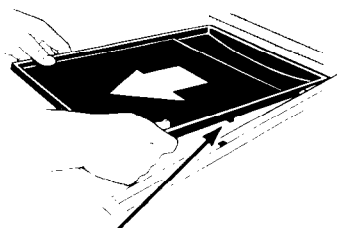

Notch on bottom of griddle

To remove and clean the griddle

Make sure the Module Control Knob is in the "OFF" position and the griddle is cool before removing or replacing.

1. Remove the griddle cover using the handle at the front.
Lift the front of the griddle, using the handle. Raise front just high enough to grasp front edge for easy removal. (See illustration at left.)
Pull slightly raised griddle toward you to unplug it.
4. Lift griddle out of cooktop.
5. Wash griddle with warm water and detergent. Do not immerse in water or use abrasive cleansers. Steel wool, metal scouring pads or harsh cleansers may scratch the non-stick finish.
6. Rinse and dry the griddle.

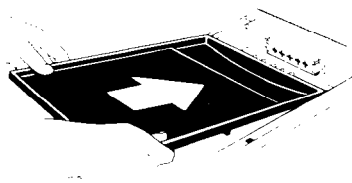

To replace griddle, line up griddle terminals with cooktop receptacle and push the griddle into position.

To replace the griddle

1. Line up griddle terminal with cooktop receptacle.
2. Push griddle into position and lower front, using the handle. The notches on each side of the griddle bottom must fit into the holes in the cooktop frame. Pull the griddle forward slightly until notches slide into the holes. The griddle will be level and firm when correctly replaced.
3. Replace the cover only over clean, cool griddle.

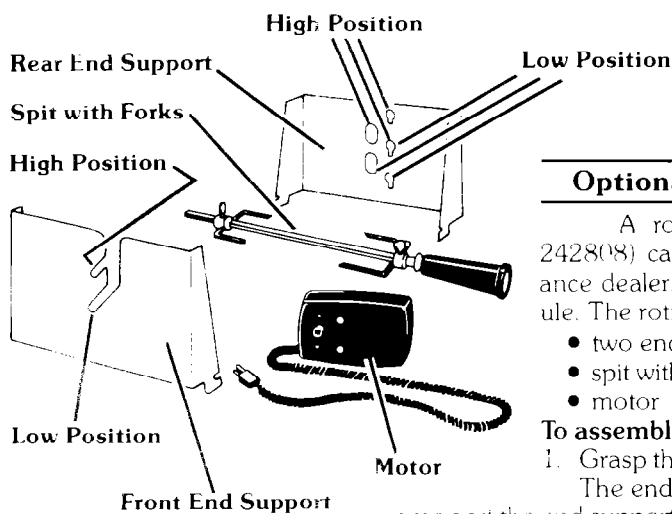

Optional rotisserie

A rotisserie kit for your cooktop (Part No. 242808) can be ordered from your Whirlpool appliance dealer. The rotisserie is used with the Grill Module. The rotisserie kit has four parts:

- two end supports for the motor and spit assembly
- spit with forks
- motor

To assemble the rotisserie:

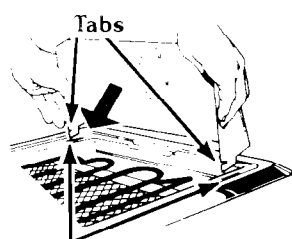

Openings in Grill Frame
Step 1

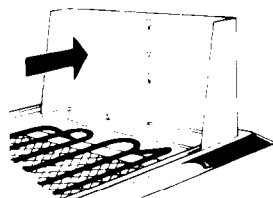

Step 2

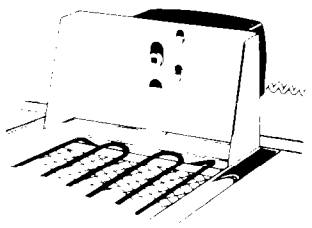

Step 3

1. Grasp the end support with two hands. (See Step 1.) The end support with five holes fits into the rear grill frame and the end support with two slots fits into the front.
 2. Fit the tabs on the end supports into the opening in the grill frame. Slide forward. Push top of the end supports back until level on the grill frame. (See Step 2.)
 3. The motor fits on the back of the rear end support in either the high or low position holes. (See Step 3.)
 4. The spit rests in a slot in the front end support. Push the end of the spit firmly into the motor socket at the rear of the cooktop. The spit and motor assembly must be placed in the same position, either high or low. (See Step 4.)
 5. The spit handle is removable, if necessary. Leave the handle in place for easier handling of the spit and meat.
 6. Take apart and clean after each use when parts are cool.
- Caution:** The end supports can become hot.

To use the rotisserie

1. Put the grill and rotisserie together as directed.
2. Place one rotisserie fork on the spit and push back toward the handle. Insert spit through the food and center so that the weight is distributed evenly as the spit turns. Place the second rotisserie fork on the spit, push both forks into the food and tighten.

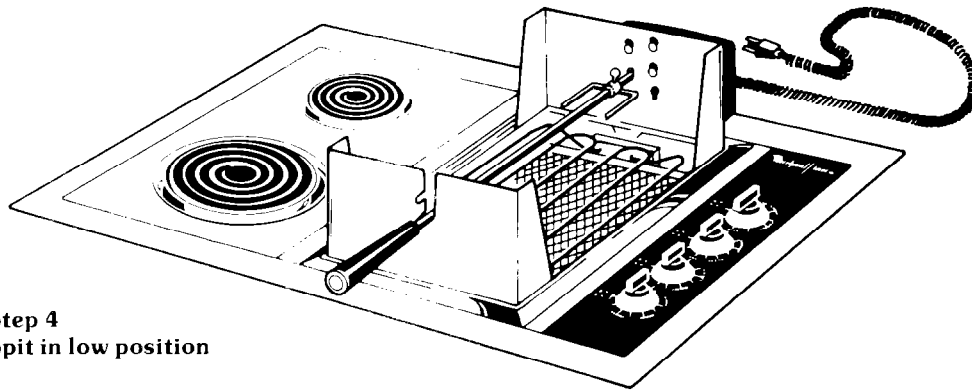

Step 4
Spit in low position

To place foods securely on spit:

Roasts Insert the spit lengthwise through the center of roasts and test for balance by rotating. Fasten the meat securely.

Ribs Weave the spit in and out of ribs forming accordion folds, keeping the ribs in balance for smooth turning and even cooking.

Poultry Place the spit through the cavity of the bird. Use the rotisserie forks to hold the legs close to the body of the bird. Tie the wings with cord, if needed. Turkeys larger than 8 to 10 pounds should be roasted rather than rotisised.

3. Place the spit with the food on the end support.
4. Push the end of the spit **firmly** into the motor socket at the rear of the cooktop.
5. See the chart for approximate cooking times.

Approximate rotisserie cooking times:

Food	Internal Temperature	Weight	Control Setting	Spit Position	Time	Comments
Beef						
Roasted rib roast	140°F	5½ lbs.	Hi	High	1 hr. 55 min.	Meat with an outer layer of fat may take longer to cook.
Roasted rump	140°F	3¼ lbs.	Hi	High	2 hrs.	
Pork						
Roasted pork roast	170°F	5 lbs.	Hi	High	3 hrs. 15 min.	
Spiced ribs	170°F	1¼ lbs.	Hi	High	50 min.	
Canadian bacon	160°F	2 lbs.	Hi	High	1 hr. 10 min.	
Lamb						
Roasted leg	175°F	5 lbs.	Hi	High	2 hrs. 30 min.	
Poultry						
Chicken	190°F	2¼ lbs.	Hi	High	1 hr. 45 min.	Truss poultry tightly. Run spit in at the base of the tail and diagonally
Turkey	190°F	6¼ lbs.	Hi	High	2 hrs. 45 min.	through the cavity to the fork of the wishbone. If
Duck	190°F	3¾ lbs.	Hi	High	2 hrs. 15 min.	wing tips brown too rapidly, cover them with foil.
Cornish hen	190°F	2-1 lb. hens	Hi	High	2 hrs.	

NOTE: Spit position: anything over two inches in diameter should be rotisised in the "High" position.

Hints and tips

1. Cooking on the rotisserie can produce spattering. Clean all parts of the rotisserie and grill after each use. Fat may become rancid and develop an odor if all parts are not thoroughly cleaned.
2. The rotisserie end supports for the spit and motor can become hot during use. Allow all parts to cool before taking apart for cleaning.
3. A tent or half circle of heavy duty foil can be placed over the rotisserie to save cooking time and grease spattering.

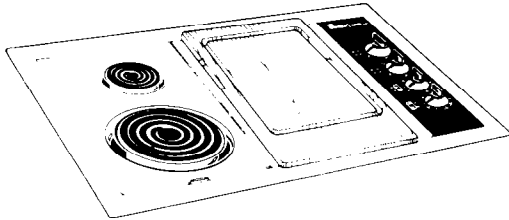

Optional cutting board

A cutting board for your cooktop (Part No. 261948) can be ordered from your Whirlpool appliance dealer.

The wood cutting board can be used in any cooktop position, on the two or three module unit.

Before using the cutting board, wipe it with a damp, sudsy cloth to remove surface dust, rinse and wipe dry.

Season it by saturating a clean cloth or paper towel with colorless mineral oil and rub it on the wood. Let oil stand a few hours, then wipe off excess.

To keep it looking new, periodically rub the surface with very fine sandpaper to remove cutting marks and stains. Clean thoroughly and re-season.

Sterilize periodically. Use a solution of one teaspoon chlorine bleach to one quart water. Saturate a clean cloth or paper towel with solution to wipe cutting board. Re-season.

If you need service or help, we suggest you follow these three steps:

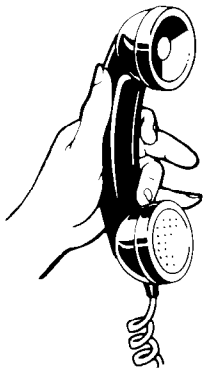

1. Before you call for service[®]:

If your cooktop does not seem to be operating properly, check the following before calling for service

If nothing operates:

- Is the cooktop wired into a live circuit with the proper voltage? (See **Installation Instructions**.)
- Have you checked the main fuse or circuit-breaker box?

If surface units will not operate:

- Have you checked the main fuse or circuit-breaker box?
- Are surface units plugged in all the way?
- Do the control knobs turn?

If surface-unit control knob or knobs will not turn:

- Did you push in before trying to turn?

If cooking results aren't what you expect:

- Is the cooktop level?
- Are the pans the size called for in the recipe?
- Are you following a tested recipe from a reliable source?
- Do the cooking utensils have smooth, flat bottoms?
- Do the cooking utensils fit the surface unit being used?



2. If you need service:

If your WHIRLPOOL® appliance ever needs service anywhere in the United States, help is just a phone call away...to your nearest Whirlpool franchised TECH-CARE® service representative.

Whirlpool maintains a nationwide network of franchised TECH-CARE service companies to fulfill your warranty and provide after-warranty service and maintenance to keep your WHIRLPOOL appliance in peak condition.

You'll find your nearest TECH-CARE service company listed in your local telephone book Yellow Pages under Washers/Dryers—Repairing or Servicing. **Should you not find a listing, dial free, the Whirlpool COOL-LINE® service assistance telephone number (800) 253-1301.**

When calling from:

- Michigan** Dial (800) 632-2243
- Alaska and Hawaii** Dial (800) 253-1121

If you move... To make sure that your appliance is correctly installed and to insure its continued satisfactory operation, please telephone your nearest TECH-CARE service company for installation or to get the name of a qualified installer. (Installation cost will, of course, be paid by you.)

Helpful hints... You can help your TECH-CARE service representative give you faster service if you include the model and serial number of your appliance when requesting service. Also, retain your sales slip and warranty to verify your warranty status.

Remember... Your TECH-CARE service representative is specially trained in the expert repairing and servicing of your WHIRLPOOL appliances. He can help you maintain the quality originally built into your WHIRLPOOL appliance. So why not take the time, now, to look up his telephone number and jot it down.

3. If you have a problem:

Call Whirlpool Corporation in Benton Harbor at the COOL-LINE service assistance telephone number (see step 2) or write:

Mr. Stephen E. Upton
 Vice President
 Whirlpool Corporation
 Administrative Center
 2000 U.S. 33, North
 Benton Harbor, Michigan 49022

If you must call or write, please provide: your name, address, telephone number, type of appliance, brand, model, serial number, date of purchase, the dealer's name, and a complete description of the problem. This information is needed in order to better respond to your request for assistance.



FSP is a registered trademark of Whirlpool Corporation for quality parts. Look for this symbol of quality whenever you need a replacement part for your Whirlpool appliance. FSP® replacement parts

will fit right and work right, because they are made to the same exacting specifications used to build every new Whirlpool appliance.



Benton Harbor, Michigan. Automatic Washers, Clothes Dryers, Freezers, Refrigerator-Freezers, Ice Makers, Dishwashers, Built-in Ovens and Surface Units, Ranges, Microwave Ovens, Compactors, Room Air Conditioners, Dehumidifiers, Central Heating and Air Conditioning Systems.

Quality. Our way of life.